

Dosing technology Dosing system

preeflow[®] eco-CONTROL EC200-B by ViscoTec



Backlit display

Start & stop keys

Mounting clips

Aluminium rack black, powder-coated

PRODUCT DESCRIPTION

The new and innovative eco-CONTROL EC200-B, made by ViscoTec offers a wide range of applications for the precision volume dosimeter of the eco-PEN series.

THEORY OF FUNCTION

Microprocessor-controlled. User-friendly. Without submenus but supported by graphics. Easy connection via I/O port to PLC of external signals for automated line control. Supports the storage of a wide range of dosing programs. Monitoring of the preset primary pressure (with pressure sensor kit only) and digital display in Bar or Psi. Monitoring of fill level and motor current alarm messages (RS232 interface included).

FUNCTIONS / PROGRAMS

- Quantity program
- Start/stop program
- Time program
- Teach-in function (external or via GPS)
- Calibration
- Desired-volume display in Grams or Millilitres
- Dosage flow rate display in Millilitres per Minute or Grams per Minute
- Empty signal for containers (internal, external)
- Storage of PDM-supported dosing programs
- Desired-pressure and actual-pressure display in Bar or Psi
- Digital clock



Connection for dispensers 1 and 2
Connection for empty-signal sensor
Connection for foot switch
Terminal strips for interfaces
RS232 interface

SD Card, 24 max
Dosing programs readable and writable with Microsoft operating system

TECHNICAL FEATURES

Control of two precision volume dosimeters of the eco-PEN series possible with a single accessory card.

Easy and user-friendly menu navigation

Plastic film keyboard with LED status displays

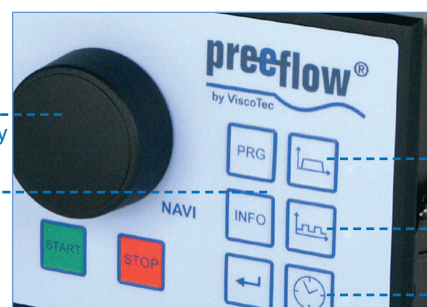

Quantity program

Start & stop program

Time program



eco-CONTROL EC200-K

Fig.: Front view
197

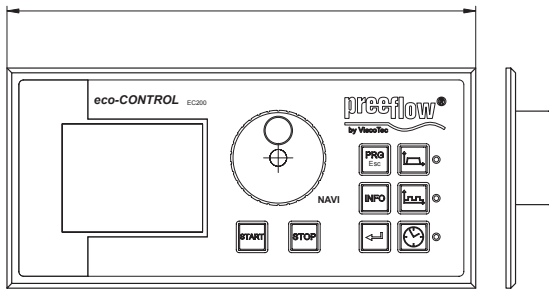

Switching cabinet dimensions
(WxH) 191 x 85 mm

Fig.: Side view

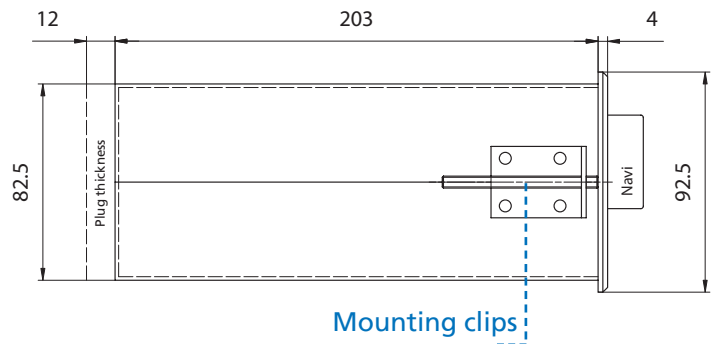

TECHNICAL DATA

| | |
|----------------------------|---|
| Dimensions (HxWxD): | 92,5 x 240 x 197 mm |
| Weight: | 980 Grams |
| Voltage: | 24 V DC |
| AC adapter voltage: | N/A (article no. 20163) |
| Power rating: | 100 VA / 2,7 A |
| Start: | Key, foot switch |
| External stop/start: | 24-V pulse, 10-mA terminal strip; 0 to 1.5V low; 12 to 24V high |
| On-off switch: | No |
| Interface: | RS232 |
| Compressed-air monitoring: | No, available on request |
| External memory: | MM CSD-Card, 64 MB min; 24 dosing programs max; |
| Operating conditions: | +10°C to +40°C, air pressure 1 bar |
| Media temperature range: | +10°C to +40°C |
| Storage environment: | Dry & dust free -10°C to +40°C |
| CE certified: | Yes |



ViscoTec Pumpen- und Dosiertechnik GmbH
Geschäftsfeld Komponenten & Geräte

Amperstraße 4 - D-84513 Töging a. Inn
Tel.: +49 (0) 8631 - 393-400
Fax: +49 (0) 8631 - 393-500
info@viscotec.de
www.viscotec.de



info@preeflow.com
www.preeflow.com